

**REDUCING COSTS OF
AN ORGANIC CHEMICAL
MANUFACTURER**

Case study

*Applying Hydranautics Integrated Membrane Solution
to recover good quality boiler feed water*

The

PROBLEM

An aromatics chemical manufacturer in Gujarat, India found they were incurring high expenses towards sending wastewater to the common effluent treatment plant (CETP). In addition, they incurred losses when they had to stop production due to CETP shutdowns



GUJARAT, INDIA



Location	Gujarat, India
Feed water source	Plant wastewater
Application	Demineralization plant feed
Capacity	824 m ³ /day
UF Design	1 rack x 12 HYDRAcap®MAX60
RO Design	2 RO trains, 85% recovery, 60 SWC5-LD

The

SOLUTION

Hydranautics proposed Integrated Membrane Solution comprising HYDRAcap®MAX60 ultrafiltration (UF) membrane modules followed by patented SWC5-LD reverse osmosis (RO) LD membranes. The wastewater was treated in a clarifier and pressure sand filter before passing to the UF-RO system.

HYDRAcap®MAX60 is a pressurized UF module and uses PVDF hollow fibers in out-to-in filtration mode. SWC5-LD membranes have enhanced membrane chemistry, innovative 34 mil thick spacer design and patented vented seal carrier, giving them unmatched performance and reliability in the industry.

Ever since plant commissioning in October 2013, it has been recovering water of good quality acceptable for boiler. The UF system is operating at a feed pressure of about 1 bar and producing filtrate of turbidity less than 0.5 NTU. Because of the fouling nature of the feed water, the UF membranes need to be maintenance cleaned 4 times in a day with alkaline chlorine solution and twice a day with acid. The RO system requires cleaning once a month. Original membranes are still in use even after 45 months of service.

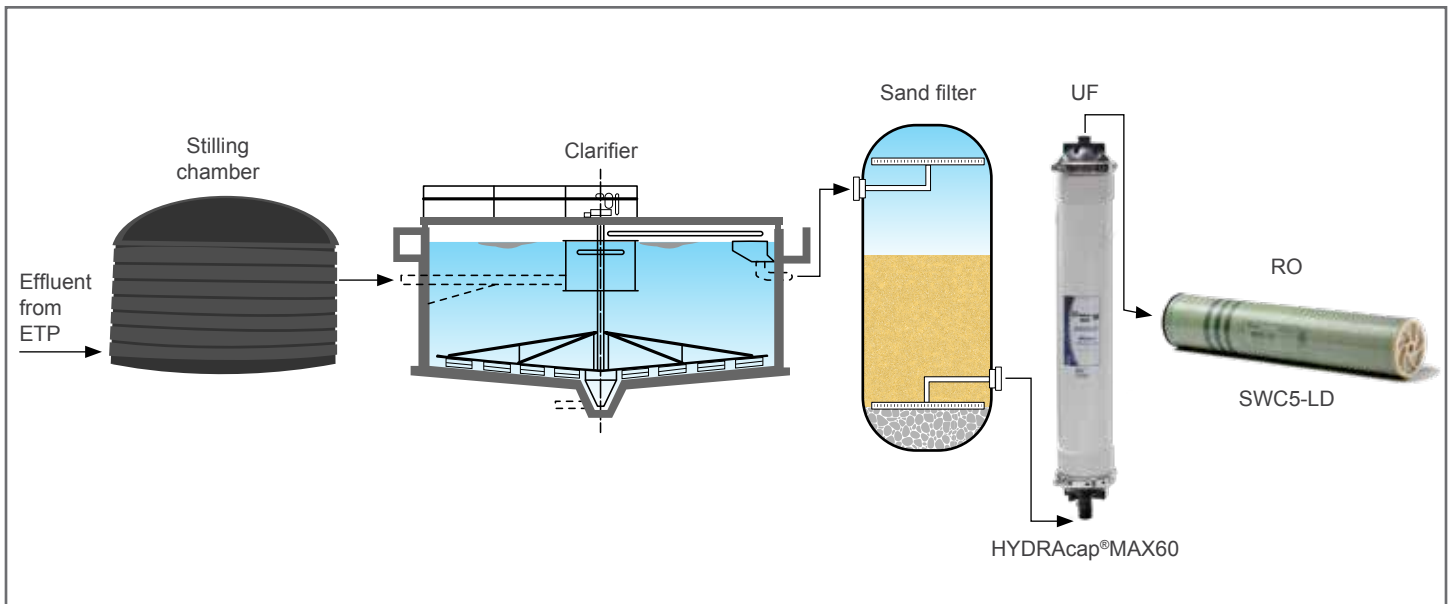

The table below shows the plant's performance.

Parameter	HYDRAcap®MAX60	SWC5-LD
Feed water quality	< 10 NTU	7,000–10,000 ppm
Treated water quality	< 0.5 NTU	< 100 ppm
Filtrate flow rate	824 m ³ /day	700 m ³ /day
Feed pressure	1 bar	16 bar
Recovery	95%	85%
Operating flux	50 lmh	14 lmh
Chemical cleaning frequency (MC: Maintenance Clean, RC: Recovery Clean, CIP: Clean-in-place)	MC with NaOH + NaOCl (4 times a day) MC with HCl (twice a day) RC with HCl (once in every 4 months)	CIP with HCl (once per month)

The IMPACT

With the Hydranautics offered Integrated Membrane Solution, the industry could save charges they earlier paid to the CETP. They could recover treated water directly for boiler feed, thus saving regeneration chemicals used

in the demineralization plant and reducing raw water intake from the river. Because of the in-house system they do not have to stop the production because of CETP problems.



About the author

MR. SACHIN PAWAR

Sachin Pawar is working as Sr. Engineer, Technology for Hydranautics – A Nitto Group Company. He has more than 10 years of experience in water treatment. He is responsible for providing technical support for Hydranautics' membrane products in the Indian subcontinent.

For more information about Hydranautics case studies, contact us at hy-info@nitto.com or visit our website at membranes.com

About Hydranautics

Since our founding in 1963, Hydranautics has been committed to the highest standards of technology research, product excellence and customer fulfillment. Hydranautics entered the Reverse Osmosis (RO) water treatment field in 1970 and is one of the most respected and experienced firms in the membrane separations industry. We joined the Osaka, Japan based Nitto Denko corporation in 1987 which was founded in 1918 and now has 117 companies in more than 20 countries, with over 30,000 employees worldwide. Our alliance with this global film industry giant boosts Hydranautics to a superior level of technological sophistication, product performance and customer response.

We are not simply product manufacturers; we are your membrane technology partners. As leaders of high quality membrane solutions, we believe our obligations extend beyond manufacturing and selling our products. Our skilled staff of technicians, engineers and service professionals assist in designing, operating and maintaining a robust, reliable and efficient membrane system to meet your requirements and exceed your expectations. Our support is offered from early stage conceptual design and engineering to start-up and maintenance, no matter the location globally whether it is on land or off-shore.

